

HEAT RECOVERY VENTILATORS  
FOR RESIDENTIAL USE



MODEL  
**VL-100EU5-E**

Wall switch type

**Energy Saving**

Reduced heat loss contributes to lower air conditioning costs.

**Fresh Air**

Simultaneous air supply/exhaust function ensures efficient ventilation.

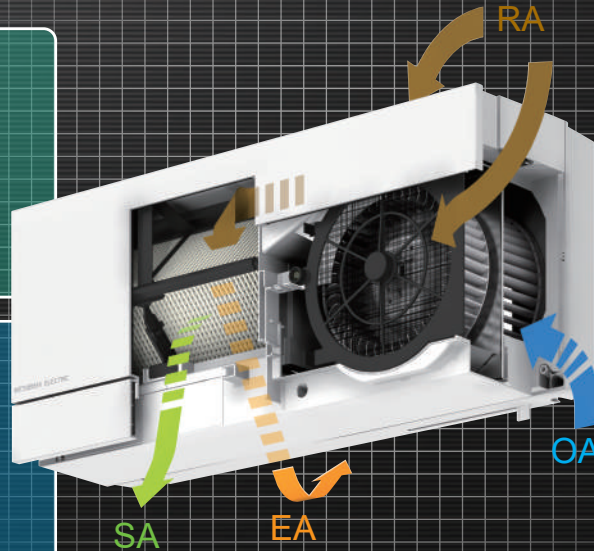

**Quiet Operation**

Equipped with sound insulation for even quieter operation.

**Simple Installation**

Easy installation through boring of 2 installation holes.

**Stylish Design**

Designed to match any interior decor.

**Total-Heat-Exchange Concept**

 **Operation in Winter**

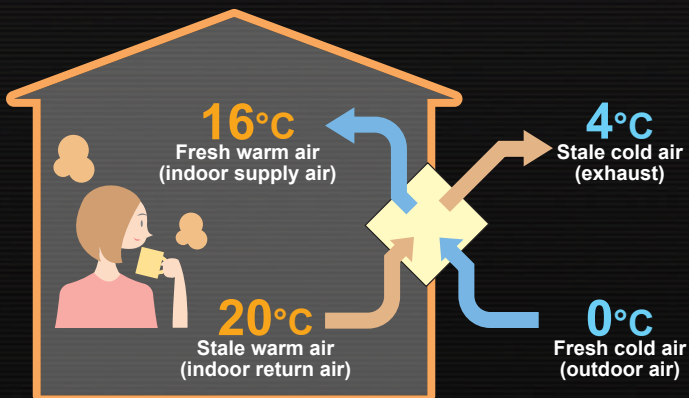

 **Operation in Summer**

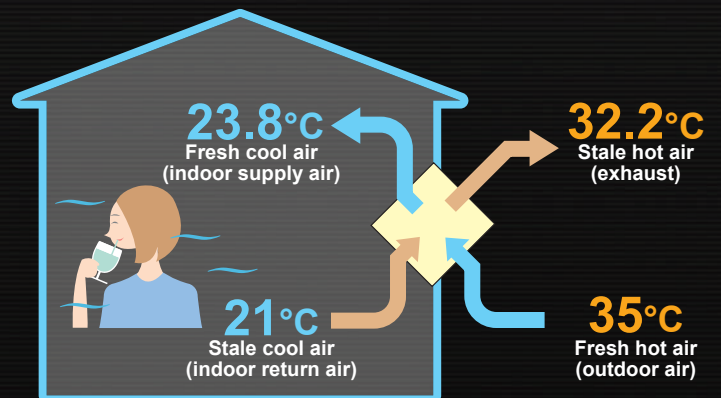

**•Heat-exchange Temp. equation**

$$\text{Indoor supply-air temperature}(\text{°C}) = \left\{ \begin{array}{l} \text{Indoor} \\ \text{temperature}(\text{°C}) \end{array} - \begin{array}{l} \text{Outdoor} \\ \text{temperature}(\text{°C}) \end{array} \right\} \times \text{Temp exchange efficiency}(\%) + \text{Outdoor temperature}(\text{°C})$$

Calculation example : 16°C = (20°C - 0°C) x 80% + 0°C (Low fan speed)

**•Heat-exchange Temp. equation**

$$\text{Indoor supply-air temperature}(\text{°C}) = \text{Outdoor temperature}(\text{°C}) - \left\{ \begin{array}{l} \text{Outdoor} \\ \text{temperature}(\text{°C}) \end{array} - \begin{array}{l} \text{Indoor} \\ \text{temperature}(\text{°C}) \end{array} \right\} \times \text{Temp exchange efficiency}(\%)$$

Calculation example : 23.8°C = 35°C - (35°C - 21°C) x 80% (Low fan speed)

## Specifications

### VL-100EU<sub>5</sub>-E (White)



Supply voltage (V)	Power line frequency (Hz)	Fan speed	Air volume (m <sup>3</sup> /h)	Power consumption (W)	Temp.exchange efficiency (%)	Noise (dB)	Weight (kg)
220	50	HI	100	30	73	36.5	7.5
		LO	55	13	80	24	
230	50	HI	105	31	73	37	
		LO	60	15	80	25	
240	50	HI	106	34	72	38	
		LO	61	17	79	27	
220	60	HI	103	34	73	38	
		LO	57	17	80	25	

- Simple installation through boring of 2 installation holes.
- Low-noise (Less than 30dB at low fan speed).
- 1-motor 2-fan system.
- Air-volume: low/high fan speeds.
- Air-supply/exhaust pipes and a plastic weather cover are included.
- Equipped with an outdoor-air shutter.
- Wall switch

## Dimensions

### VL-100EU<sub>5</sub>-E

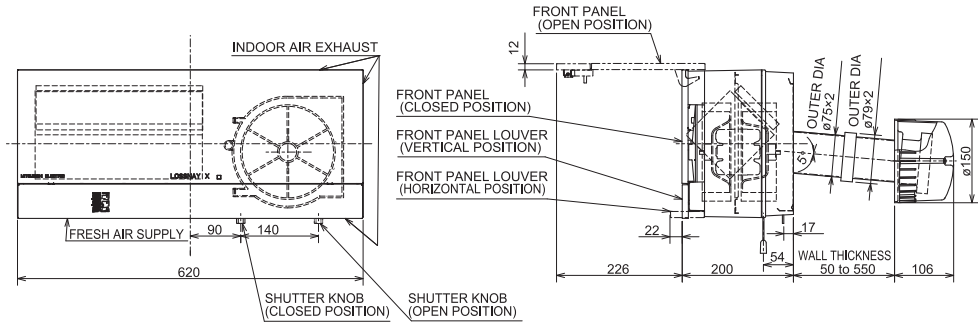
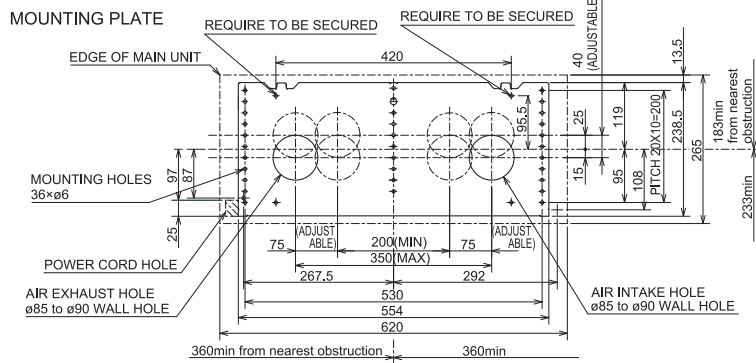

(unit: mm)

## Wiring Diagram

### VL-100EU<sub>5</sub>-E

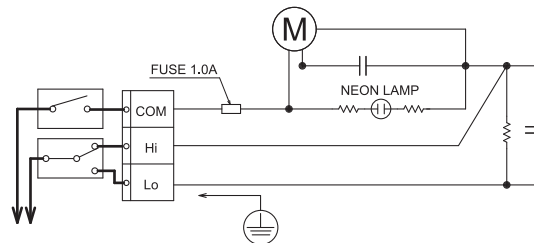

## Optional parts

### High performance filter P-100HF<sub>5</sub>-E

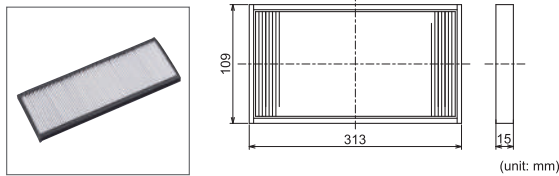

- Upgraded high-performance filter.

### Replacement filter P-100F<sub>5</sub>-E

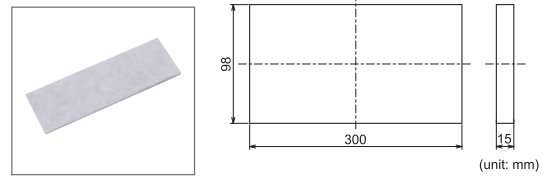

- Standard grade replacement filter.

### Extension Pipe P-100P-E

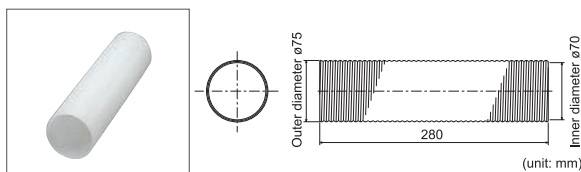

- Total length when connected to the pipe extension coupling is 300mm.

### Extension Pipe Coupling P-100PJ-E

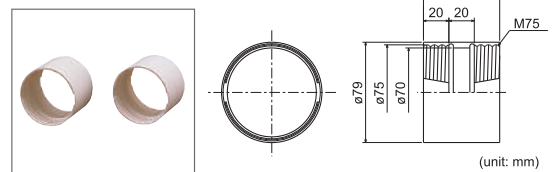

- Screw-in method